

# STANDARD WOOD SIDE AND REAR YARD FENCE

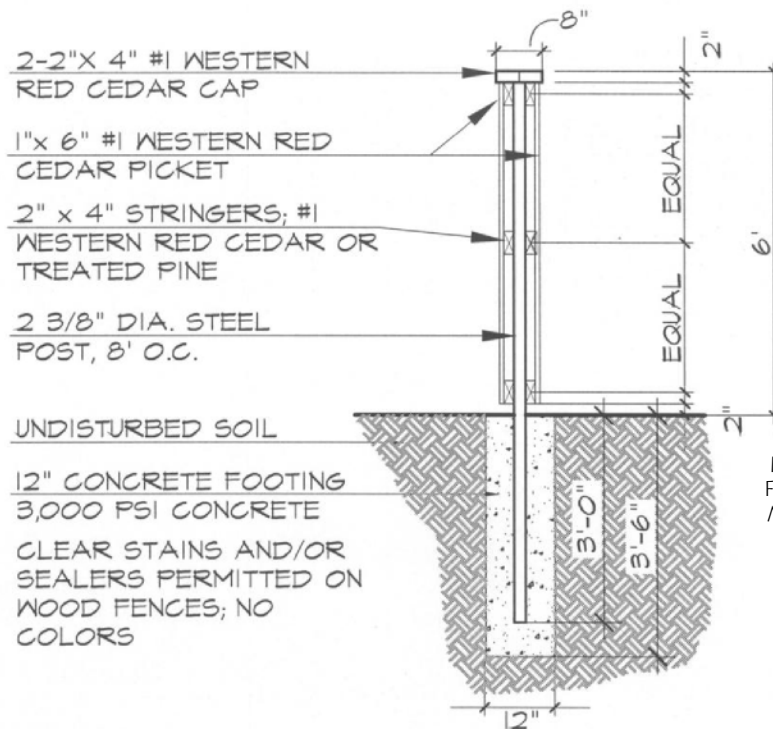

NOTE: BOTTOM OF FENCE TO FOLLOW GRADE; TOP OF FENCE MAINTAINS LEVEL ELEVATION W/ GRADE CHANGE TO BE ACCOMPLISHED BY STEPPING FENCE PANELS IN 6" INCREMENTS

NOTE: FENCING ON THE DOWNHILL SIDE AND THE REAR OF EACH LOT IS REQUIRED TO BE BUILT BY EACH LOT OWNER. OWNER SHALL FACE EXTERIOR SIDE (THE SIDE FACING AWAY FROM SUBJECT LOT) OF WOOD FENCES. OWNER WILL BE REIMBURSED AS BELOW. IF LOT OWNER BUILDS UPHILL SIDE FENCE, OWNER WILL BE REIMBURSED AS BELOW BY THE OWNER OF THE ADJACENT, UPHILL LOT WHEN CONSTRUCTION BEGINS ON THE ADJACENT LOT.

IF OWNER HAS ENTERED INTO A SIDE-FENCING CONSENT AND WAIVER AGREEMENT, EXHIBIT O-1, AND INTERIOR SIDE IS FACED, LOT OWNER AGREES THAT OWNER(S) OF ADJACENT LOT(S) MAY FACE EXTERIOR SIDE OF WOOD FENCE. OWNER WILL BE REIMBURSED AS BELOW.

OWNER(S) OF ADJACENT LOT(S) WILL REIMBURSE OWNER OF SUBJECT LOT FOR 50% OF COST OF MATERIALS, PERMITTING AND INSTALLATION OF STANDARD WOOD FENCE, EXCEPT FOR THE COST OF THE INTERIOR SIDE OF WOOD FENCE, WHEN CONSTRUCTION BEGINS ON ADJACENT LOT(S). IF EXTERIOR SIDE IS FACED, OWNER OF ADJACENT LOT WILL REIMBURSE OWNER OF SUBJECT LOT 100% OF COST OF FACING EXTERIOR SIDE.

SEE STANDARDS FOR FURTHER DETAIL. SEE FENCE/RETAINING WALL EXHIBIT 'M' FOR FENCING BUILT ATOP RETAINING WALLS.



WHITTIER HEIGHTS

EXHIBIT O

**WOOD FENCING CONSENT AND WAIVER AGREEMENT**

This **WOOD FENCING CONSENT AND WAIVER AGREEMENT** is entered into as of the Effective Date listed below by ("Owner") for the benefit of the **Whittier Heights Architectural Control Committee** (the "Whittier Heights ACC") and future adjacent lot owners.

**WHEREAS**, Owner has or will purchase Lot \_\_\_\_\_, Block ----- in Whittier Heights, an addition to the City of Colleyville, Tarrant County, Texas (the "Lot"), which Lot is located at \_\_\_\_\_, Colleyville, Texas 76034; and

**WHEREAS**, the Whittier Heights Aesthetic Standards require that side fences and rear fences be constructed on the Lot and be "faced" to the outside, such that the vertical facing boards are built on the outer portion of the fence, facing outside the Lot, and fence posts, top rails, and other support railing are built on the inner portion of the fence, facing into the Lot (the "Facing Requirement"); and

**WHEREAS**, Owner desires that the Facing Requirement be waived and Owner be allowed to build downhill side and/or rear fences facing the Lot; and

**WHEREAS**, the Whittier Heights ACC is willing to waive the Facing Requirement on the condition that Owner agree to the following terms and conditions, as well as the other requirements and standards propagated by Whittier Heights ACC or to which the Lot is otherwise subject;

**NOW, THEREFORE**, for and in consideration of the waiver and consent herein granted and other good and valuable consideration the receipt and sufficiency of which is hereby acknowledged, Owner and Whittier Heights ACC, agree as follows:

1. The Whittier Heights ACC hereby waives the Facing Requirement as it applies to the Lot.
2. Owner agrees to construct side and/or rear fencing along the Lot boundaries that face inside the Lot but otherwise meets all standards, requirements and necessary approvals of the Whittier Heights ACC.
3. Owner agrees that, whereas the side and rear fences built by Owner shall be the property of Owner, adjacent lot owners bordering the respective sides of the Lot shall have full use and enjoyment of the side and/or rear fences bordering their respective properties. Such an adjacent lot owner may, at its election, "face" the common fence toward its lot, employing the fence posts and support rails and attaching vertical boards thereto according to fence specifications of the Whittier Heights Aesthetic Standards. In the event of such election, Owner may require the adjacent lot owner to pay one-half the reasonable amount of Owner's cost of the materials, labor and permitting attributable to installation of the fence posts, stringers, caps and other structural elements of the Whittier Heights Standard Wood Fence, as described in the Whittier Heights Aesthetic Standards and Requirements. If the parties cannot otherwise agree, the reasonableness of such costs shall be determined by the Whittier Heights ACC in its absolute discretion.
4. Owner agrees that the rights granted to adjacent lot owners in paragraph 3 above shall apply regardless of whether the side and/or rear fences are built precisely along the common lot boundary line, or wholly or exclusively on the Lot-side of the boundary.
5. Owner acknowledges that this agreement is made for the benefit of adjacent lot owners, the identity of whom may not yet be determined. It is intended that such adjacent lot owners have full rights of enforcement as thirdparty beneficiaries with respect to paragraphs 3 and 4 above.

This agreement is entered into effective as of the \_\_\_\_ day of \_\_\_\_\_, 200\_\_ (the "Effective Date").

**OWNER:**

**WHITTIER HEIGHTS  
ARCHITECTURAL CONTROL COMMITTEE:**

By:  
Name: \_\_\_\_\_

By: 

By: Name:



# STANDARD STEEL FENCE

NOTE: FOR PET CONTROL,  
CLOSER PICKET SPACING, 2"  
O.C. WILL BE ACCEPTED

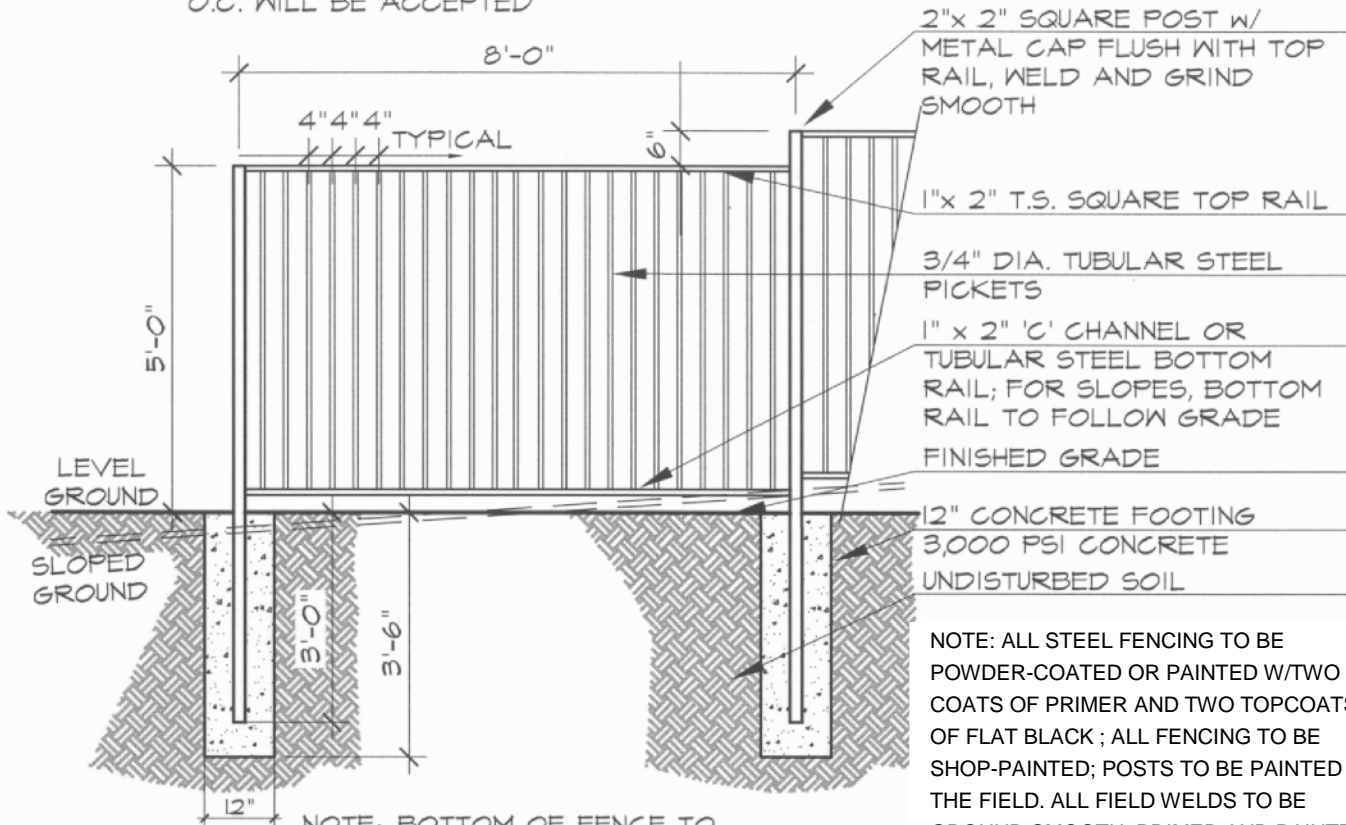

- 2" x 2" SQUARE POST w/  
METAL CAP FLUSH WITH TOP  
RAIL, WELD AND GRIND  
SMOOTH
- 1" x 2" T.S. SQUARE TOP RAIL
- 3/4" DIA. TUBULAR STEEL  
PICKETS
- 1" x 2" 'C' CHANNEL OR  
TUBULAR STEEL BOTTOM  
RAIL; FOR SLOPES, BOTTOM  
RAIL TO FOLLOW GRADE
- FINISHED GRADE
- 12" CONCRETE FOOTING  
3,000 PSI CONCRETE  
UNDISTURBED SOIL

NOTE: ALL STEEL FENCING TO BE  
POWDER-COATED OR PAINTED W/TWO  
COATS OF PRIMER AND TWO TOPCOATS  
OF FLAT BLACK ; ALL FENCING TO BE  
SHOP-PAINTED; POSTS TO BE PAINTED IN  
THE FIELD. ALL FIELD WELDS TO BE  
GROUND SMOOTH, PRIMED AND PAINTED  
PER ABOVE SPECIFICATIONS.

CONTRACTOR SHALL CLEAN UP  
AND REMOVE 'SLAG' AFTER  
FIELD WELDING, AS IS  
CONSISTENT W/ FINE  
CRAFTSMANSHIP

NOTE: BOTTOM OF FENCE TO  
FOLLOW GRADE; TOP OF  
FENCE MAINTAINS LEVEL  
ELEVATION W/ GRADE CHANGE  
TO BE ACCOMPLISHED BY  
STEPPING FENCE PANELS IN 6"  
INCREMENTS

NOTE: ALL TERMINAL AND CORNER  
POSTS TO BE 3 X 3" SQUARE POST W/  
METAL CAP FLUSH WITH TOP RAIL;  
WELD AND GRIND SMOOTH



WHITTIER HEIGHTS

EXHIBIT P

# STANDARD STEEL FENCE ON REAR PROPERTY LINE

NOTE: FOR PET CONTROL,  
CLOSER PICKET SPACING, 2"  
O.C. WILL BE ACCEPTED

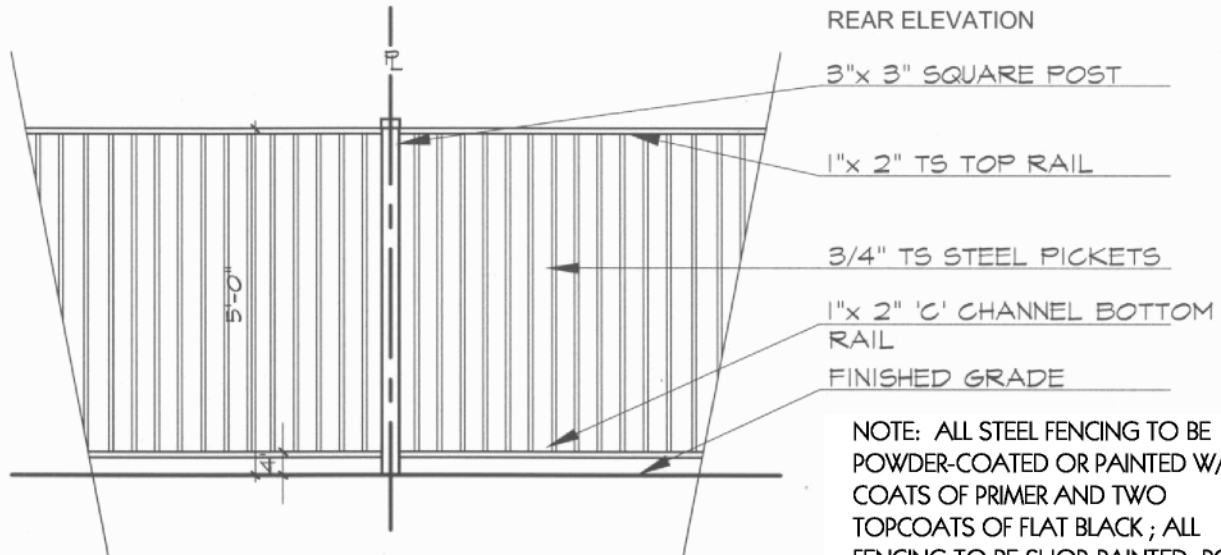

NOTE: BOTTOM OF FENCE TO FOLLOW GRADE; TOP OF FENCE MAINTAINS LEVEL ELEVATION W/ GRADE CHANGE TO BE ACCOMPLISHED BY STEPPING FENCE PANELS IN 6" INCREMENTS

NOTE: ALL STEEL FENCING TO BE POWDER-COATED OR PAINTED W/TWO COATS OF PRIMER AND TWO TOPCOATS OF FLAT BLACK ; ALL FENCING TO BE SHOP-PAINTED; POSTS TO BE PAINTED IN THE FIELD. ALL FIELD WELDS TO BE GROUND SMOOTH, PRIMED AND PAINTED PER ABOVE SPECIFICATIONS.

CONTRACTOR SHALL CLEAN UP AND REMOVE 'SLAG' AFTER FIELD WELDING, AS IS CONSISTENT W/ FINE CRAFTSMANSHIP

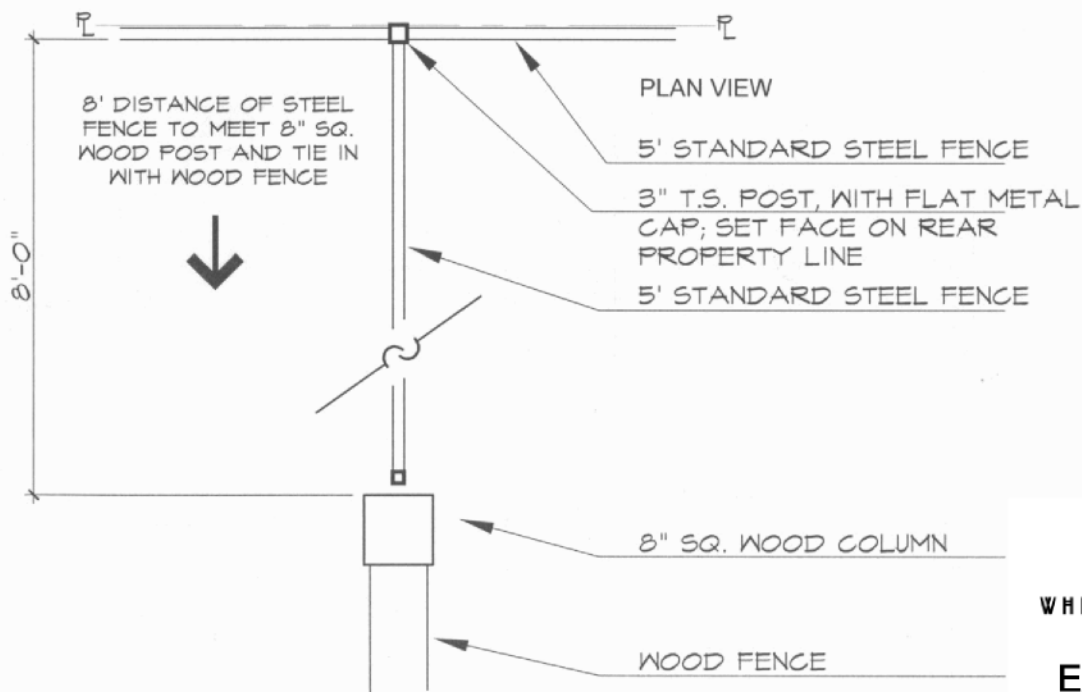

WHITTIER HEIGHTS

EXHIBIT P-1